

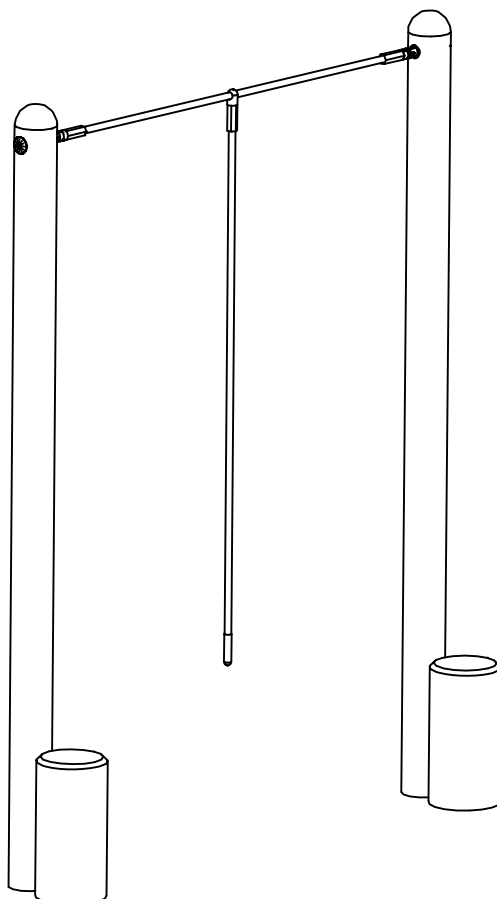

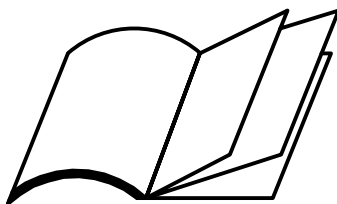

Bringing together leading brands in the play industry

INSTALLATION INSTRUCTIONS
PILLARS OF HERCULES
EC221S & EC221B



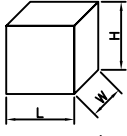
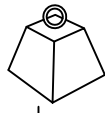
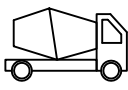
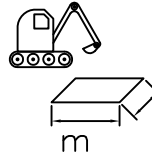
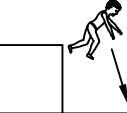

Section 1:

	 LxWxH (m)	 kg	 m ³	 m	 ≥EN1176	 x 2 = T
EC221S	2.23 X 0.40 X 2.81	197.00	0.44	3.00 X 1.00	1.80 m	T = 3h
EC221B		210.00	0.48			

TYPE 1/2/3  101/144

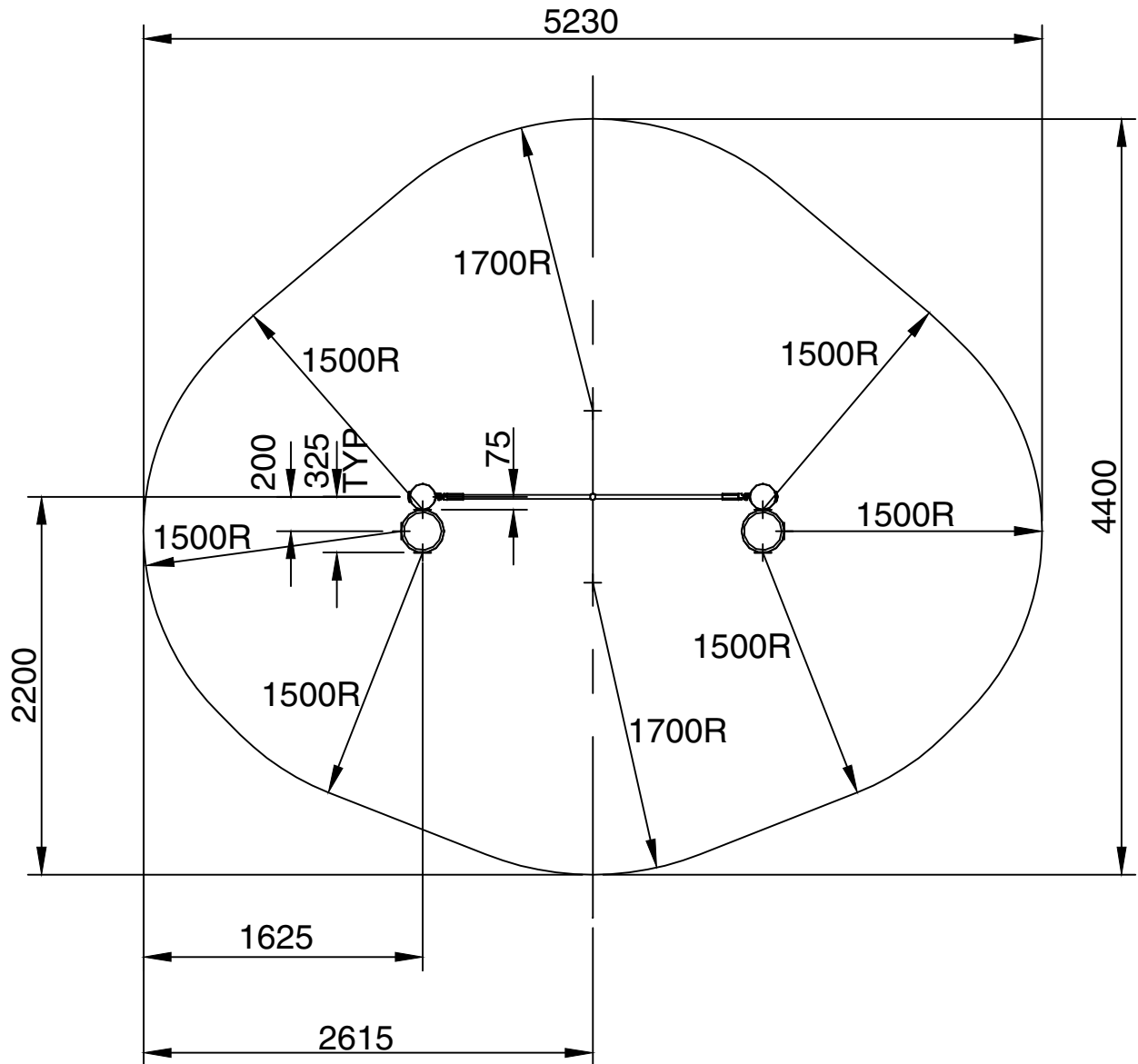
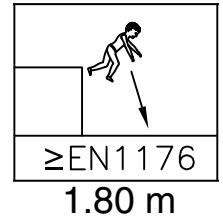

EC221B

TYPE 1/2  101/144

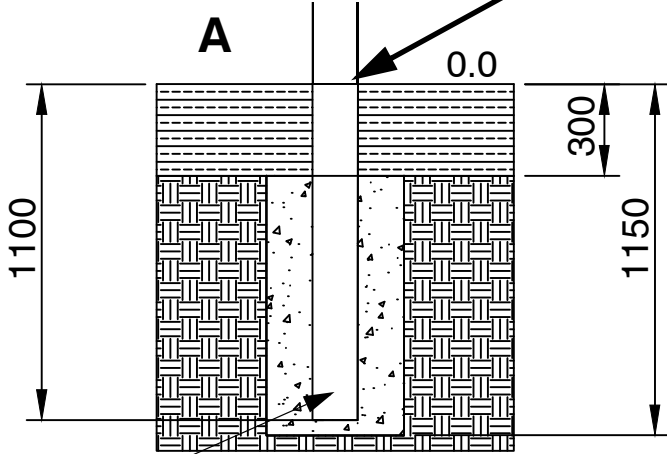
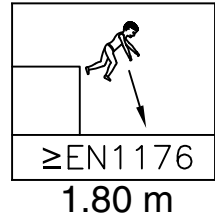
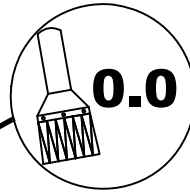

1 LTB11

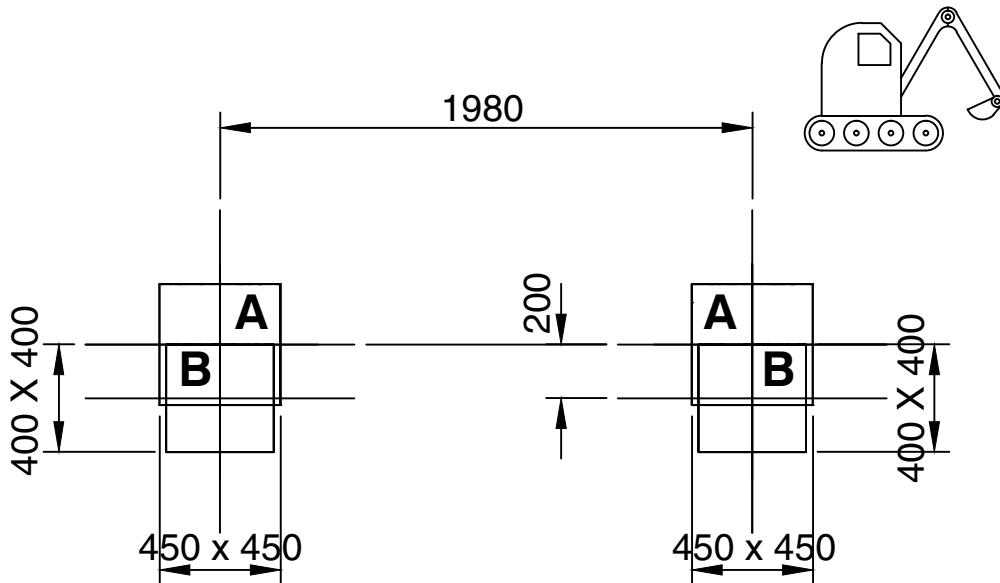
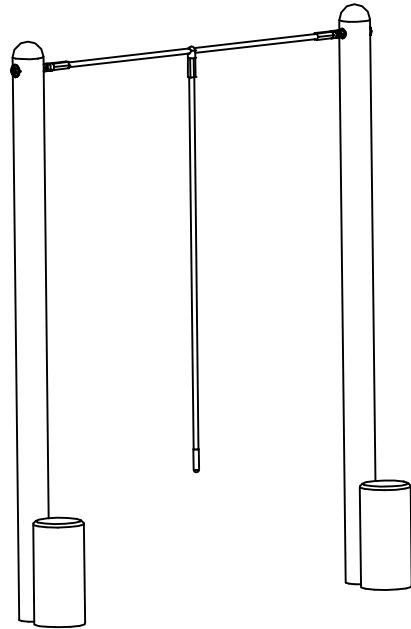
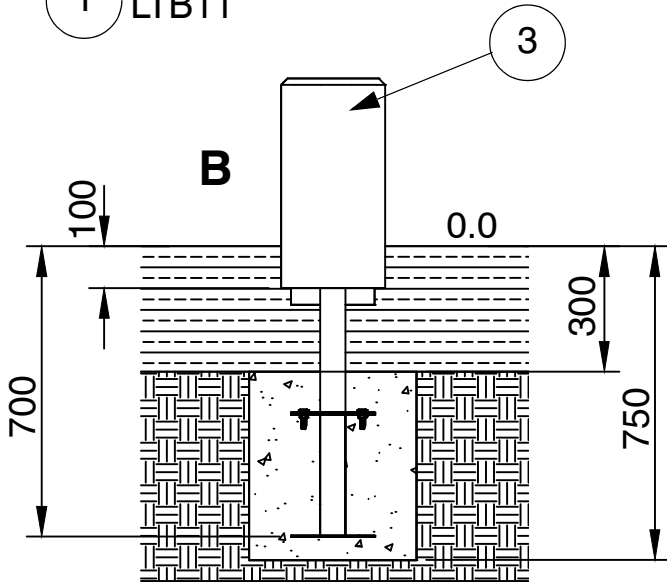

EC221S



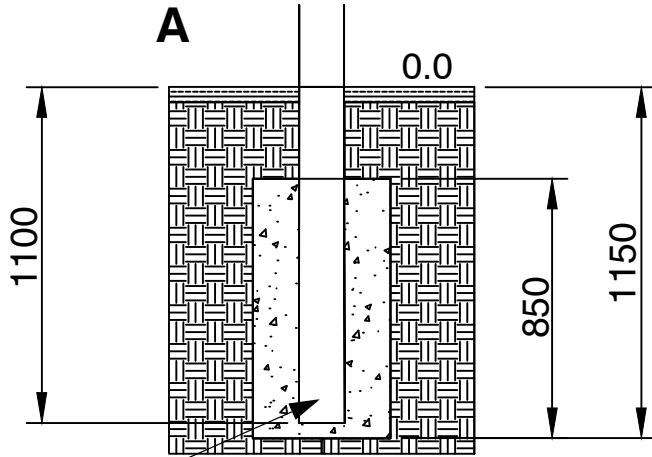
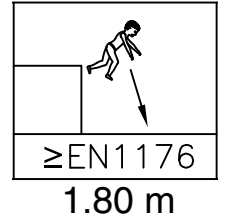

TYPE 3  101/144

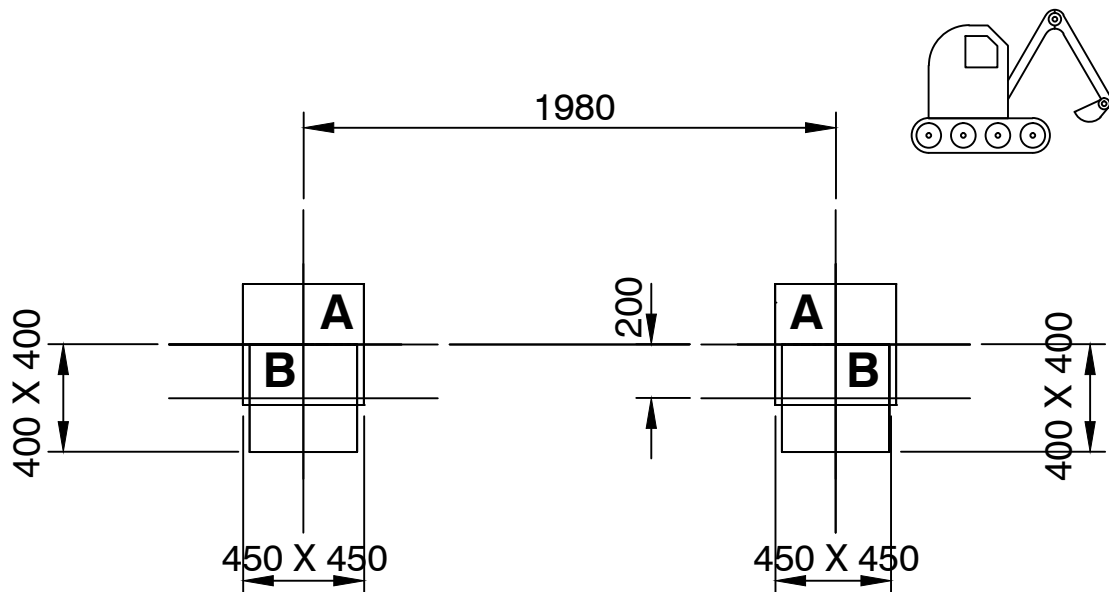
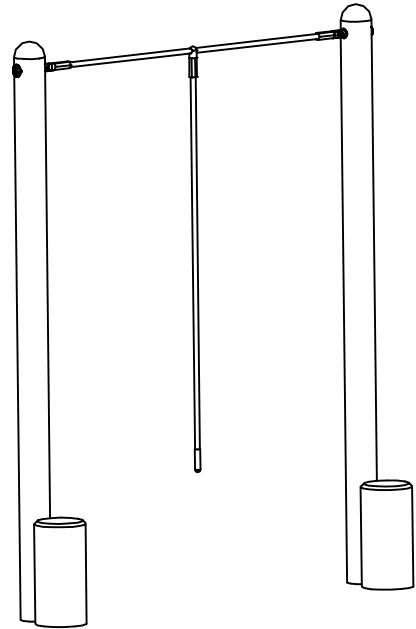
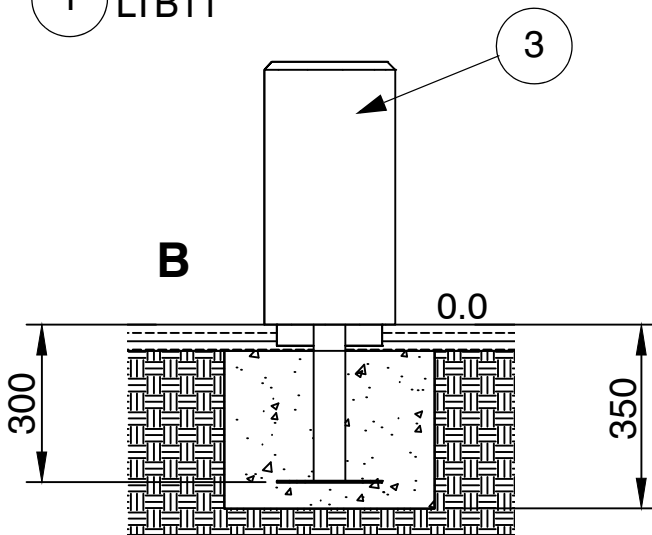

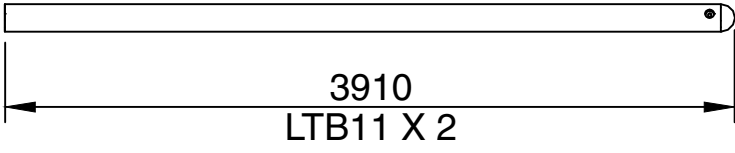
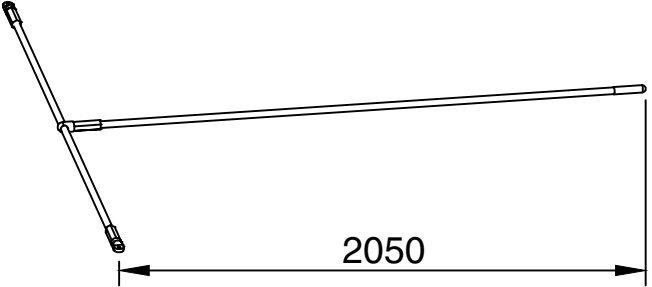
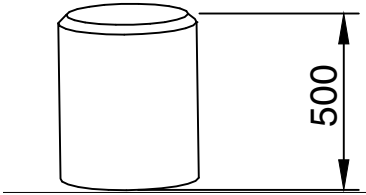
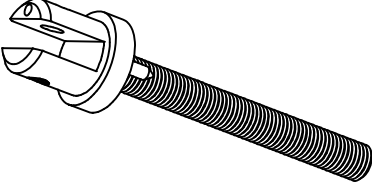
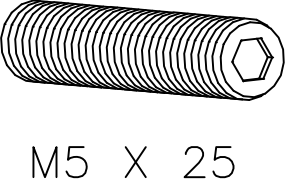
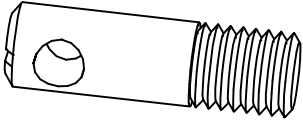
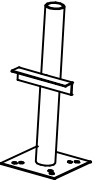
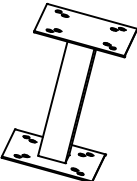
1 LTB11

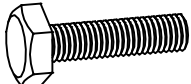
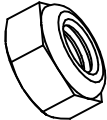
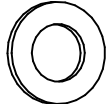
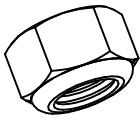
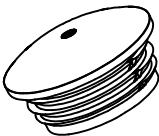

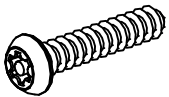
ITEM	REF		EC221S	EC221B	kg
1	781-006		1		70.40 X 2
2	780-505		1		6.0
3	RYBL500		2		18.00
4	780-593		2		0.4
5	780-594		2		0.003
6	780-595		2		0.02
7	803705		2		7.00
8	305802			2	6.0

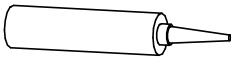
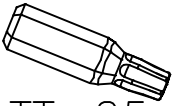
ITEM	REF		EC221S	EC221B	kg
9	10231040	 M10 X 40		8	0.05
10	10261000	 M10		8	0.01
11	10381600	 M16 17X30X3		2	0.007
12	10321600	 M16		2	0.031
13	786-904			2	0.023
14	782-000	 SMP (PLAYGROUNDS) Ltd EQUIPMENT CONFORMS TO EN1176 (2008)		1	0.05
15	10051025			4	0.03
16	RYADHBK	  Aro-Seal 1132 Polyurethane Sealant http://www.alansonsuk.com/downloads.asp		1	-
17	10120400	 TT-25		1	-

STEP 1

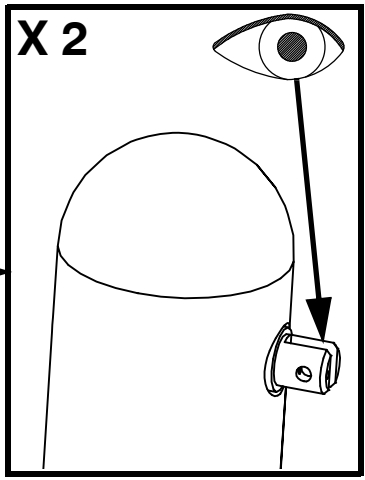
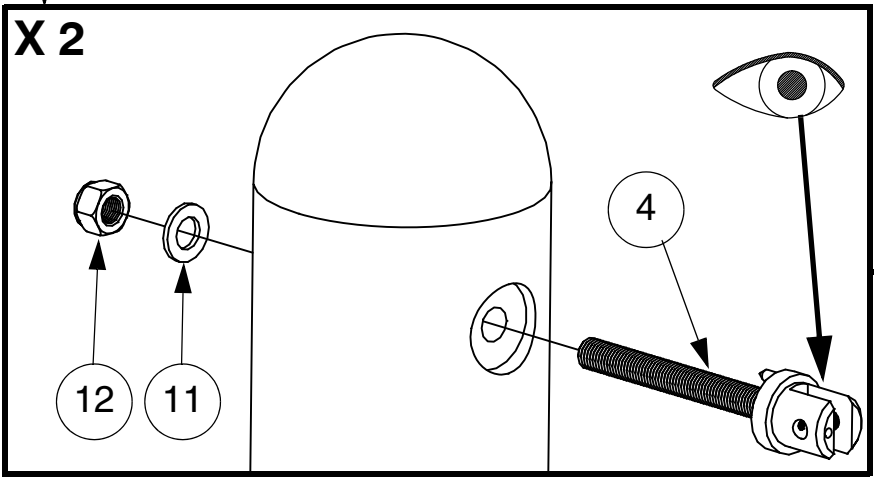
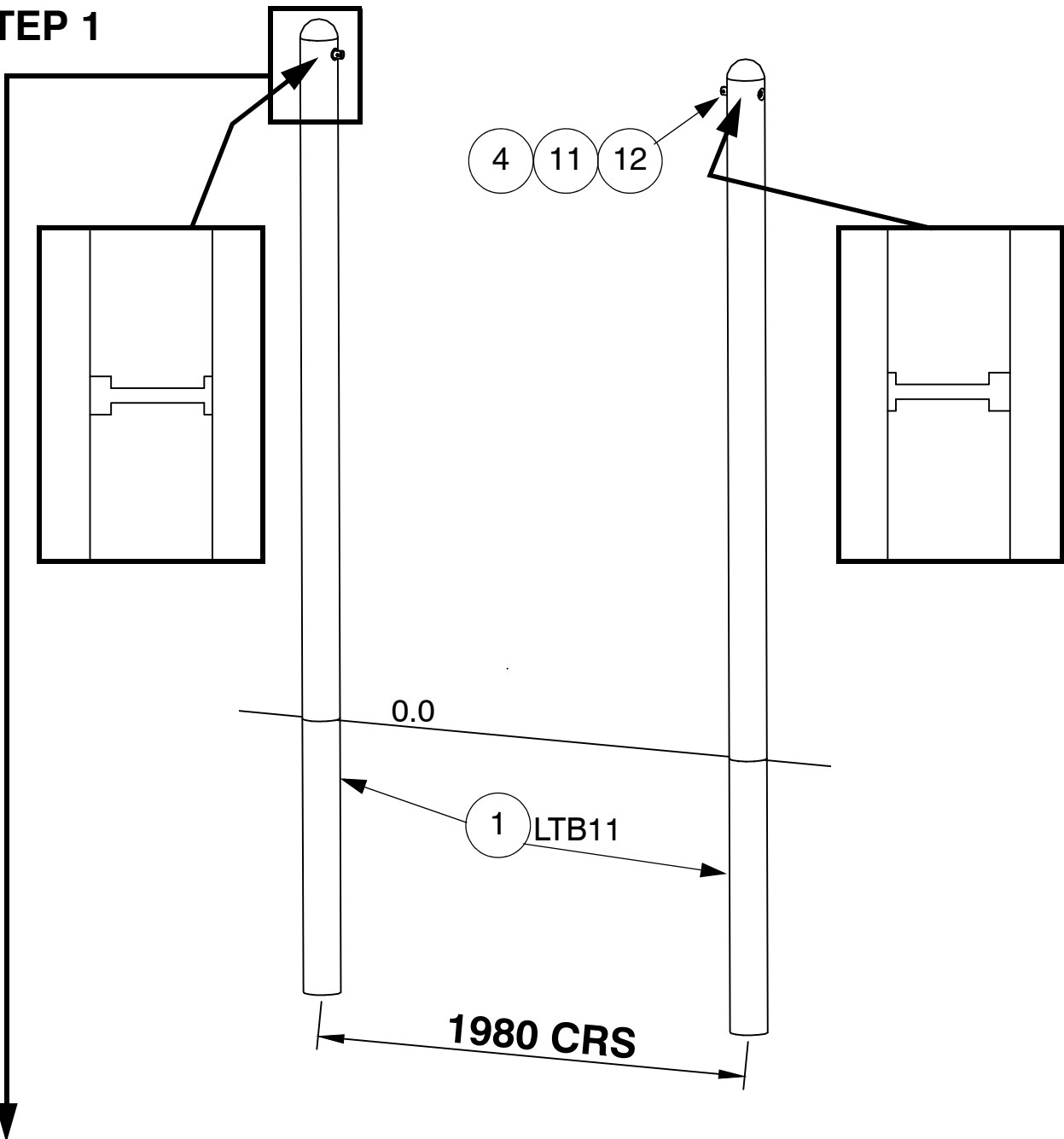

STEP 2A - EC221B TYPE 1/2   **4**

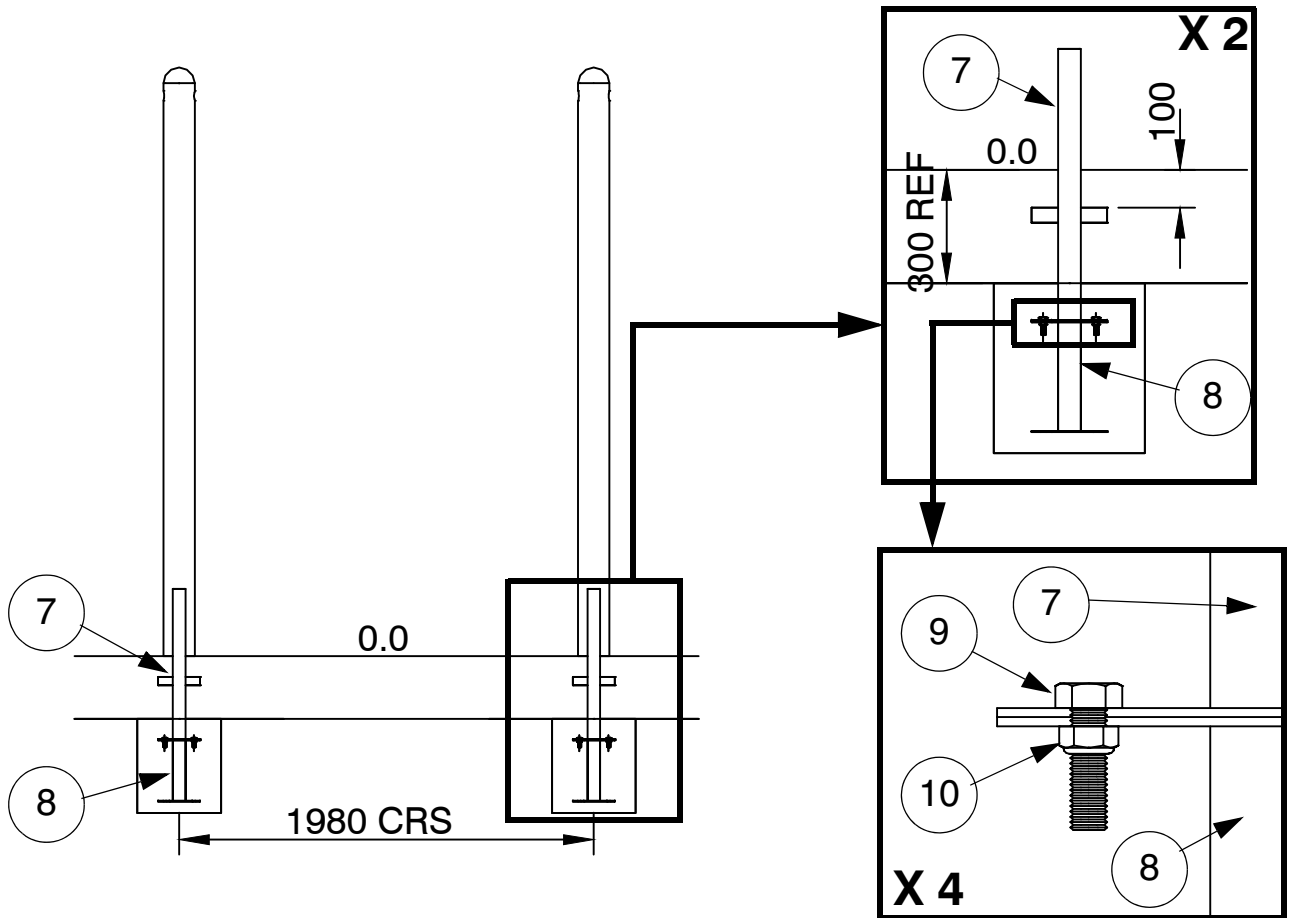

STEP 2B - EC221S TYPE 3   **5**

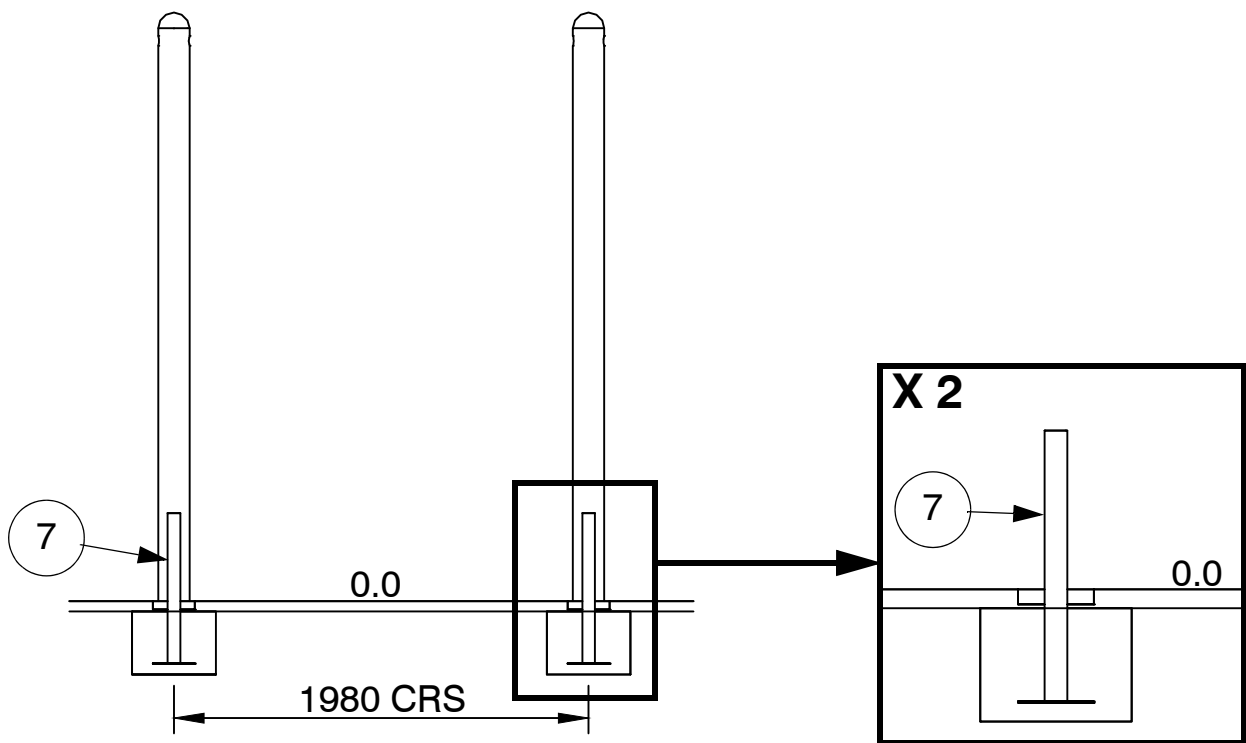

STEP 3

GB - VERIFY ROPES FIT - REMOVE BEFORE CONCRETING
 ES - UTILIZAR LAS CUERDAS PARA VERIFICAR LA DISTANCIA ENTRE LOS POSTES - QUITARLAS ANTES DE PONER EL HORMIGÓN
 FR - UTILISER LES CORDES POUR VÉRIFIER LA DISTANCE ENTRE LES POTEAUX - LES RETIRER AVANT BÉTONNAGE
 DE - ÜBERPRÜFEN SIE, DASS DIE SEILE PASSEN - VOR DE BETONIERUNG
 IT - USARE LE CORDE COME DISTANZIALI - RIMUOVERLE PRIMA DI CEMENTARE I PALI
 SE - KONTROLLERA ATT DE LINORNA PASSA - FLYTTAS INNAN BETONGARBETE

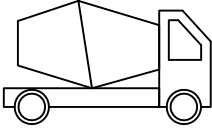

S2 (50mm)
 ≥C20-25
 7 x 24h
 101



STEP 4

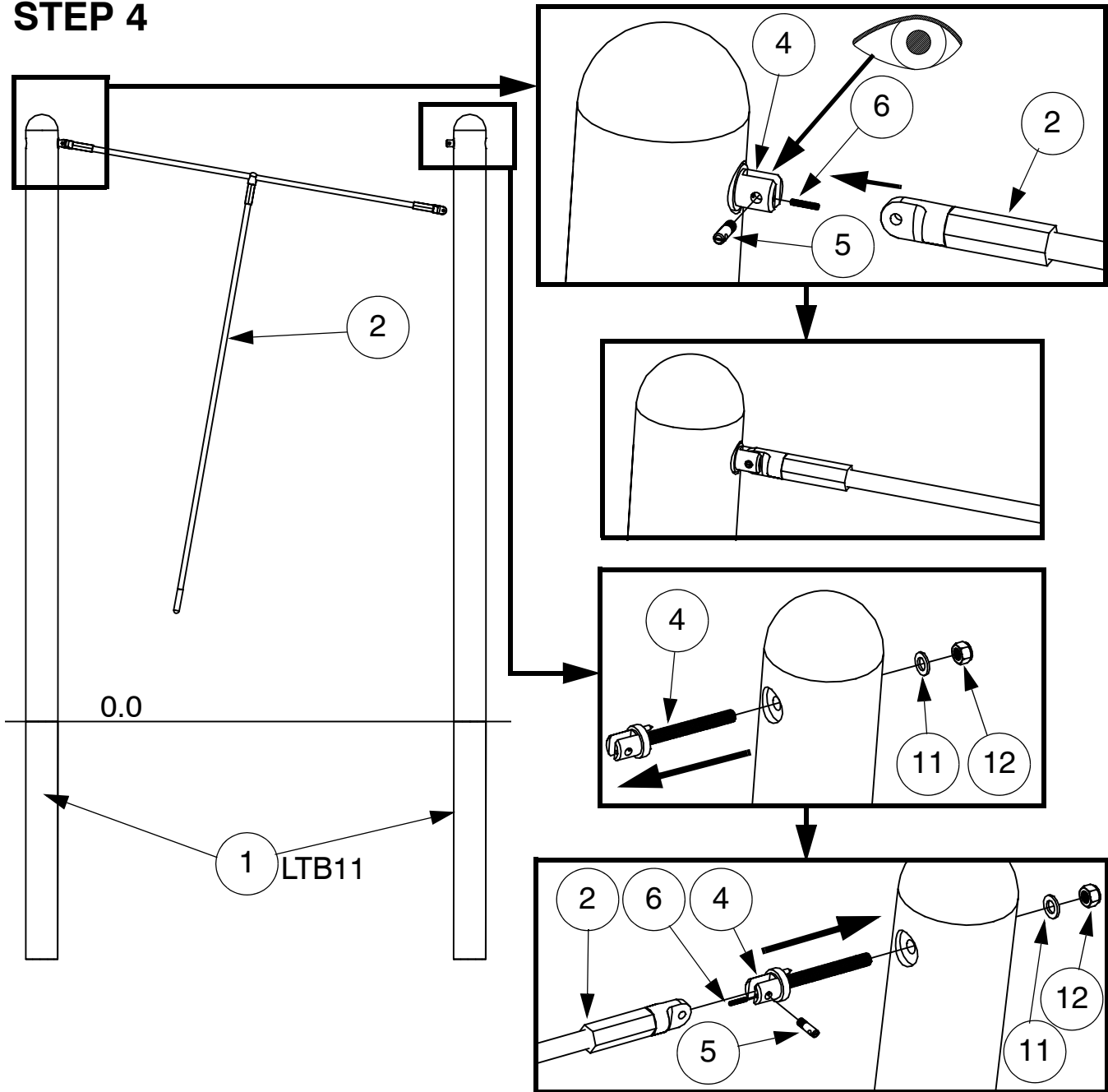

STEP 5

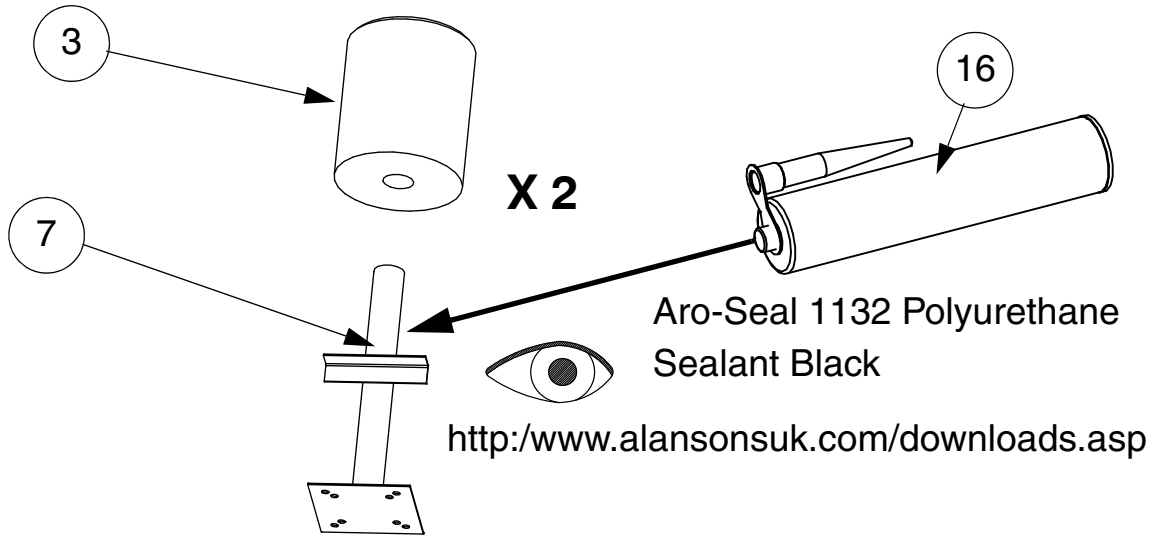

STEP 6

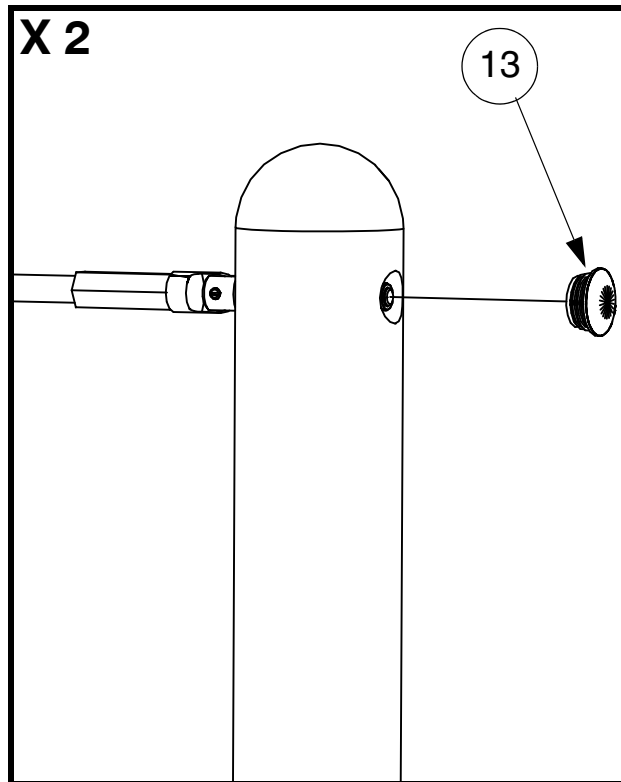

STEP 7

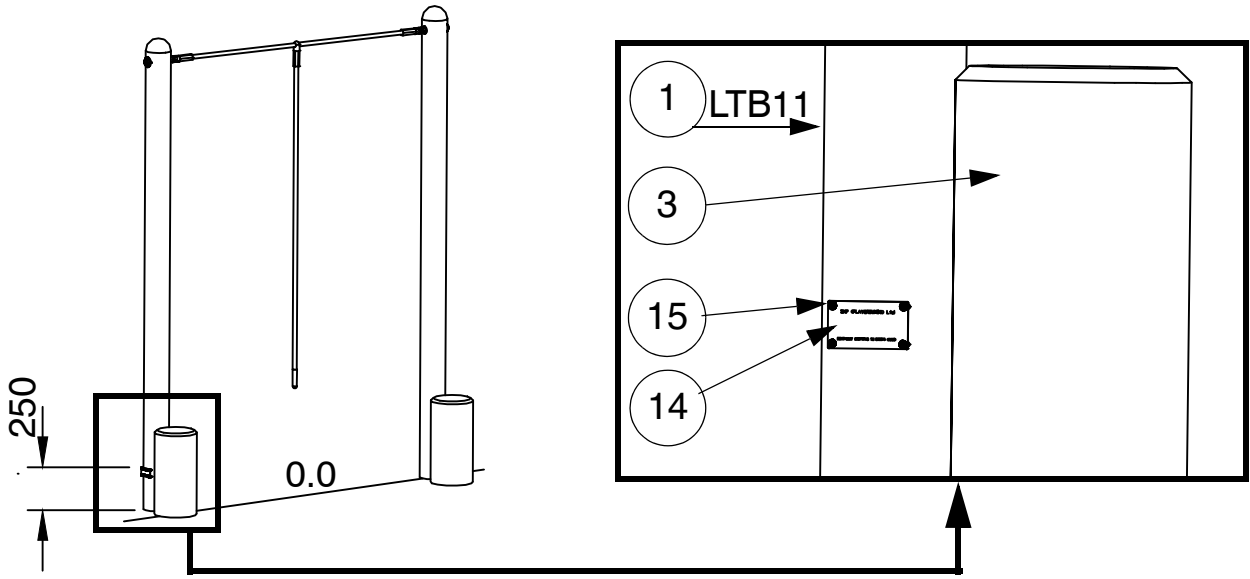

STEP 8

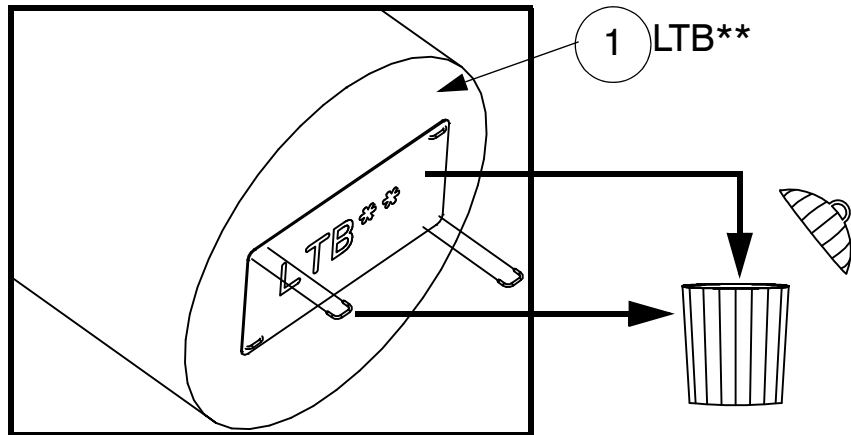

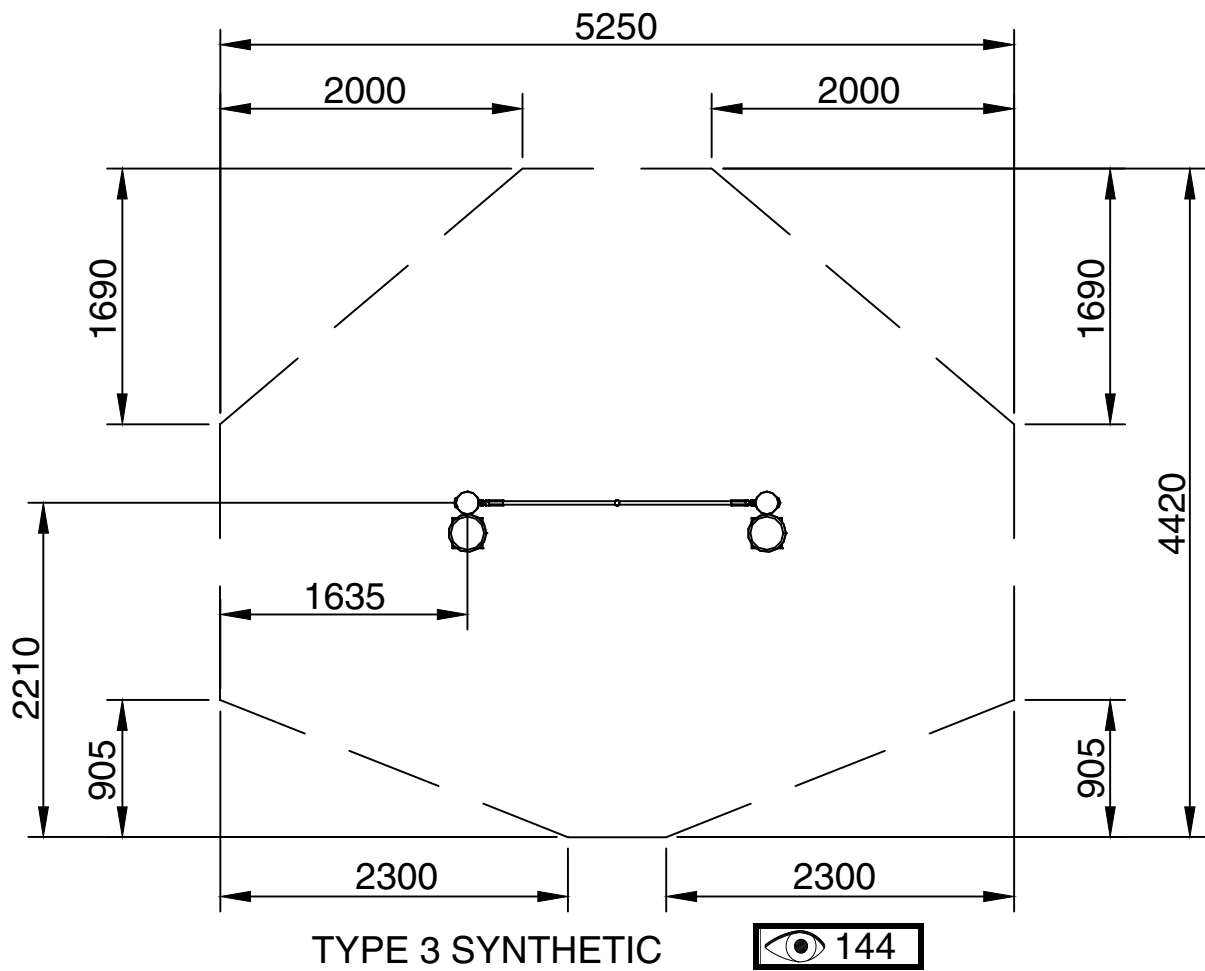
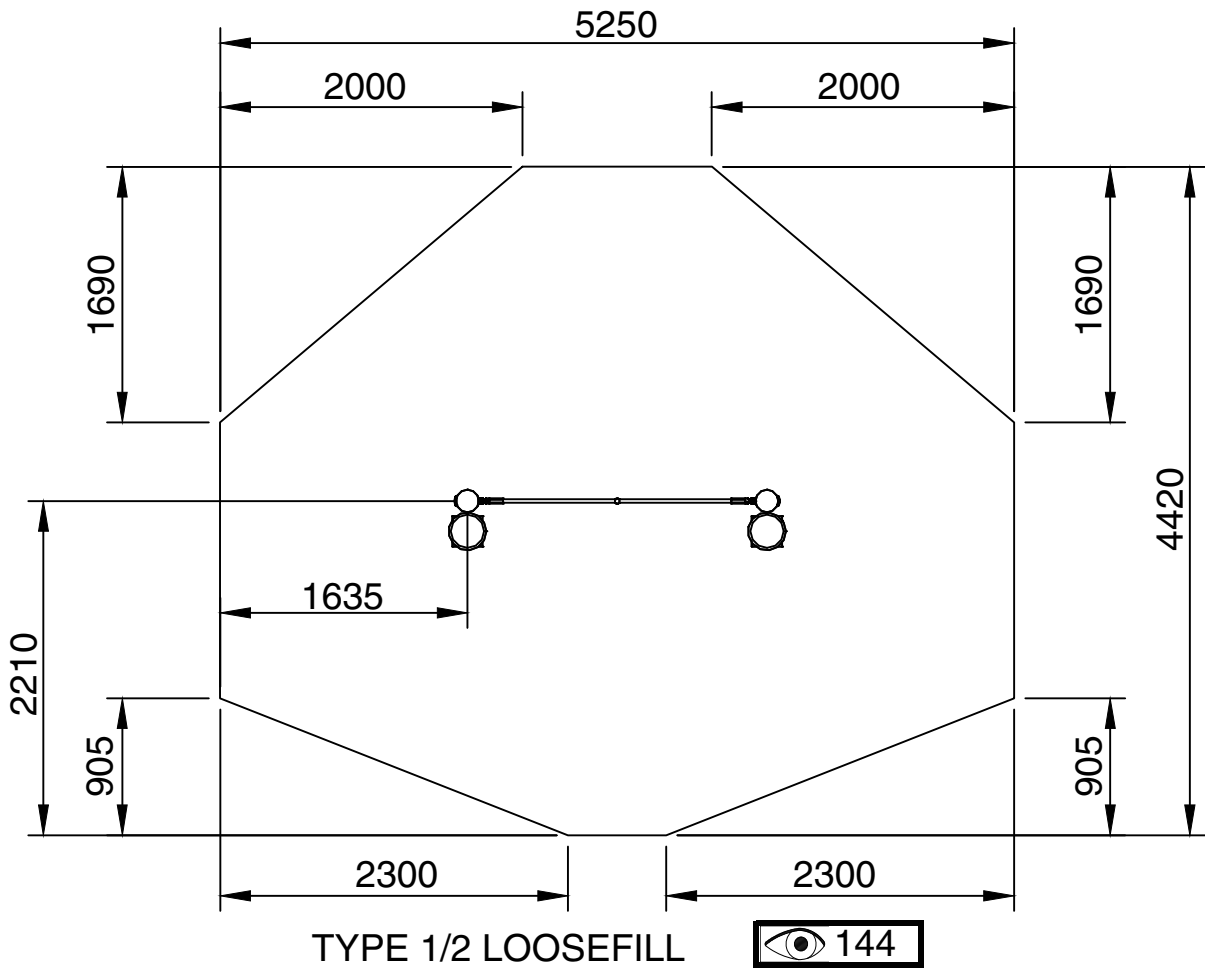

Appendix A:

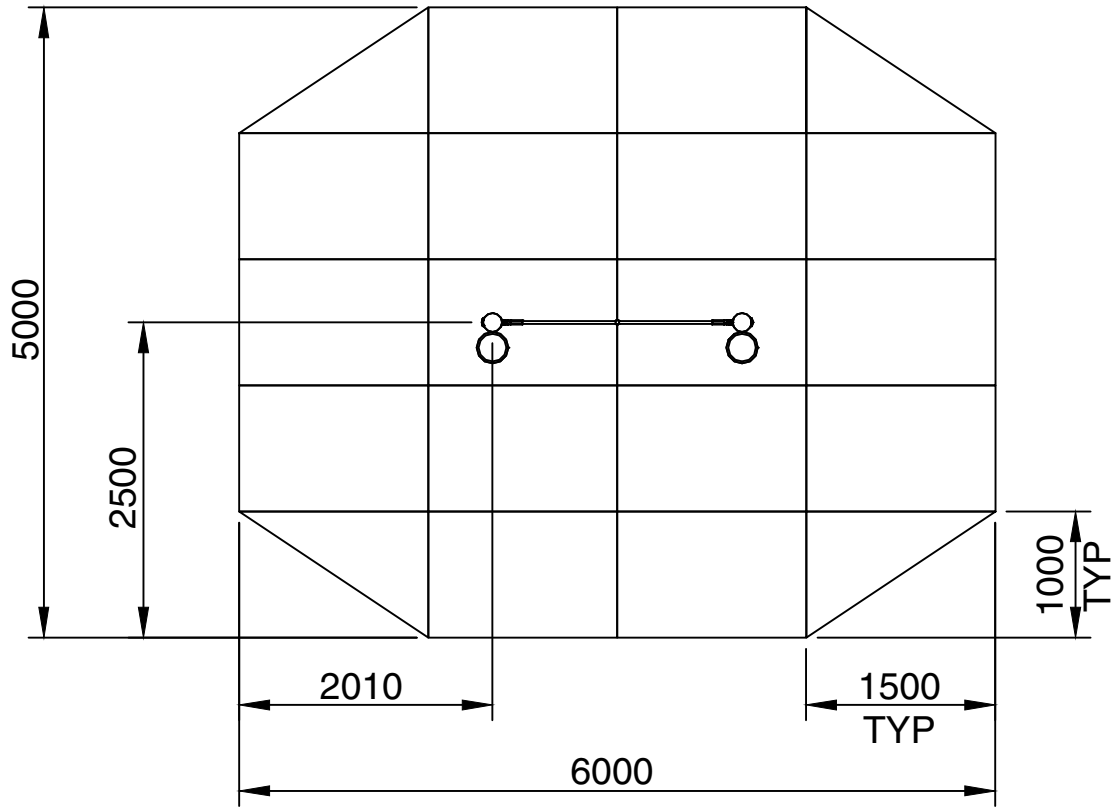

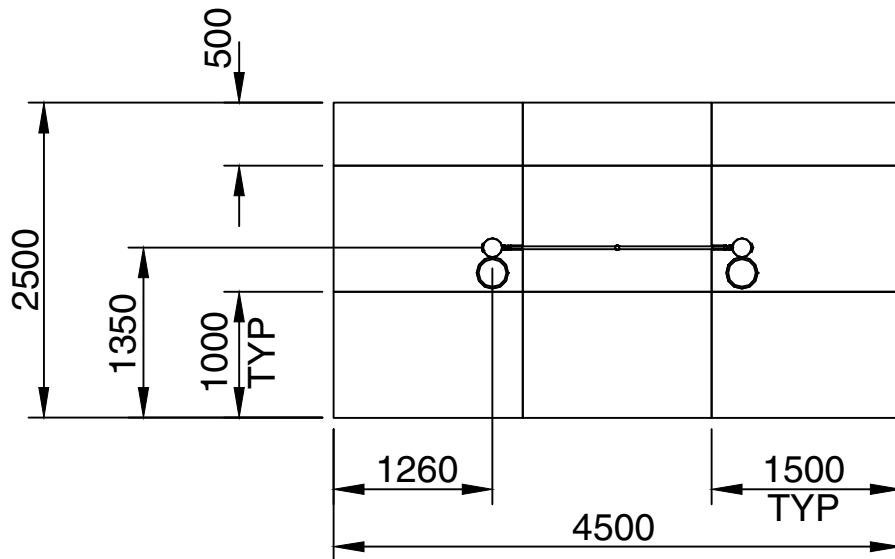

TYPE 5 GRASSMATT FR  144



TYPE 5 GRASSMATT FR - WEAR AREA  144

1 SAFE WORKING PRACTISE

A full risk assessment should be carried out prior to commencing the installation, which will be specific to the site selected. The major risks associated with purely the assembly of this product are highlighted below, which can form part of this overall assessment.

1.1 RISKS:

- i) Large parts which could be difficult to lift or handle.
- ii) Structure unstable until concrete footings have fully cured.
- iii) Parts at height that may require working overhead.
- iv) Heavy parts at height that require support during assembly

1.2 CONTROL MEASURES:

- i) Warn the public of the risk of injury, by placing signs and fencing the surrounding area, before commencing installation.
- ii) All staff working on installation to wear suitable PPE including Toe Protective Shoes, Hard hat and Gloves.
- iii) Any staff or other persons on site, not working directly on the installation, to be kept away from the installation.
- iv) Ensure adequate personal and equipment are on site to handle and support the structure whilst it is being assembled.
- v) Suitable working platform to provide secure access and provide support for parts required.

2 SPECIFICATIONS

SMP Playgrounds Ltd recommends an effective *Impact Absorbing Surface tested to EN1177 & BS7188* beneath this play equipment. Refer to manufacturers instructions for details of installation. The surface should have a Critical Fall Height greater than the Maximum Free Fall Height of the equipment.

Constructional Space is the approximate working area required to lay out and assemble the equipment.

For the safe operation of this equipment it must be installed on horizontal ground with the required minimum space.

The concrete foundations indicated are for average ground. Care should be taken concerning abnormal conditions.

If a loose fill surface is selected for this item it will require a very high level of maintenance to ensure a sufficient thickness is in place at all times to provide 'critical fall height' protection.

3 PREPARATION

All equipment assembly and fixing must conform to EN1176.

Tools / ancillary equipment: Plumblines, 5m tape measure, spirit level, TT-25 fixing tool (supplied with unit), metric socket set - inc 10-24 sockets, 3m reach ladder, 2.5mm AF Allen Key.
Loose fill: Masking tape, Paint brush, Black paint.

3.1 ESTABLISH ORIENTATION

- vi) Measure out the site to ensure the space required fits into the allotted area, it is horizontal and free from trip points or other obstructions.
- vii) Ensure the equipment is to be provided with an effective Impact Absorbing Surface which has a tested critical fall height rating greater than the maximum Free Fall Height of the equipment.

3.2 MARK OUT HOLES

Consult SMP layout drawing for structure position on site.

See **page 4 & 5** for concrete foundation sizes.

NOTE: This is a minimum guide only.

3.3 ESTABLISH DATUM LEVEL

- i) If a rubber tiled Impact Absorbing surface is to be laid, see separate instructions (base may incorporate up to 2% falls etc).
- ii) If equipment is to sit in loose fill or wet pour rubber surfaces allowances will need to be made for its recommended thickness. Generally it is recommended that loose fill surfaces are installed to a depth of 300mm, however, with certain loose fill materials an alternative depth may be required. This will need to be determined by allowing 100mm for the dispersal in addition to the thickness required for the particular Free Fall Height. The foundation illustrated will allow for a thickness up to 300mm.

PRE-INSTALLATION INSPECTION

Inspect all parts for damage (that may have occurred during transportation & storage). Finish Coatings, if found to be damaged these should be made good before erection (Refer to maintenance instructions). Any damaged or missing parts must be replaced.

4 INSTALLATION & ASSY PROCEDURES

- i) Refer to site layout for position and orientation of product, then, mark the outline of the position of the footings with e.g. spray or chalk etc. Excavate the holes. **(SEE PAGE 4/5)**.
- ii) Fit 1 off BTN 135 Bolt (item 4) to each Upright Post (item 1 - LTB11), secure using 1 off M16 Washer (item 11) and M16 Nyloc Nut (item 12). Check counterbores and holes are clear, ensure BTN Bolts are located in the shallow counterbore on inside of posts. Ensure slots of the BTN Bolts are inline vertically as shown (rope must pivot vertically only) and the pins are pulled into the grain of the timber when tightened. **(SEE STEP 1)**.
- iii) Place Upright Posts (item 1 - LTB11) into designated excavations, ensure BTN Bolts (item 4) on both posts are facing inward. Brace in position and ensure all the posts are level, plumb and spaced to correct dimensions, this is critical for correct tension of the rope. **(SEE PAGES 4 & 5, STEP 1)**
- iv) Place 2 Bollard Fixing Posts (item 7) into designated excavations, brace in position taking notice of surface type and requirements. For Type 1/2 attach Bollard Fixing Posts (item 7) to Extension Posts (item 8) using 8 off M10 X 40 Hex. Bolt (item 9) and M10 Nut (item 10). **(SEE PAGES 4 OR 5 & STEP 2A OR 2B)**.
- v) Verify rope fits - remove before concreting. **(STEP 3)**.
- vi) Fill the holes with concrete to the required level, taking into account any Impact Absorbing Surfacing requirements. Ensure that the full volume of concrete is used. The top of the concrete should gradually (1:100) slope down & outwards locally from the equipment upstand to the required level to form a watershed.

Concrete mix is recommended at:

1 part cement;
2 parts sand;
4 parts aggregate;
by volume with 20mm aggregate
(20 N/mm² min compressive strength)

- vii) Keep installation off limits to the public until the concrete has completely cured. (Recommended initial curing time is 48 hours). **(STEP 3)**.
- viii) If installation is with a loose fill type (type 1/2) surface, the upright posts should be marked with 'Basic level mark' to indicate the recommended finished surface level. **(SEE PAGE 4)**.
- ix) Remove any installation aids before fitting rope. Fit one end of Rope (item 2) to one of the BTN 135 Bolts (item 4) located at the top of an Upright post (item 1- LTB11), ensuring the rope is the correct way up, secure using 1 off Pivot Bar (item 5) and M5 X 25 Grub Screw (item 6), utilise 2.5mm AF Allen Key ensuring grub screw goes fully into hole of pivot bar to full depth of BTN fitting. Fully tighten, allowing the rope to hang freely. **(SEE STEP 4)**.

- x) Upon the other Upright Post (item 1 - LTB11), remove the BTN Bolt and it's fixings, connect the Rope (item 2) to the BTN Bolt using 1 off Pivot Bar (item 5) and M5 X 25 Grub Screw (item 6), utilise 2.5mm AF Allen Key ensuring grub screw goes fully into hole of pivot bar to full depth of BTN fitting. Place the BTN Bolt back within the counterbore on the Upright Post and secure using 1 off M16 Washer (item 11) and M16 Nyloc Nut (item 12). Check counterbore and hole is clear, ensure BTN Bolt is located in the shallow counterbore on inside of post, with slot positioned vertically (rope must pivot vertically only) and pulled into the grain of the timber when tightened. **(SEE STEP 4).**
- xi) Fit Bollards (item 3) to Fixing Posts (item 7). Apply adhesive (item 16) to Fixing Post (item 7) and slide Bollard (item 3) onto post until fully home. (Refer to instructions provided with adhesive). **(STEP 5).**
- xii) Fit 2 off Black PLastic Caps (item 13) to cover fixings within available counterbores of all posts. **(STEP 6).**
- xiii) Ensure Manufacturers label (item 14) is fitted to outside of an Upright Post (item 1 - LTB11) as shown, 250mm up from Finish Surface Level (0.0) using 4 off 1" Self Tapping Screw (item 15). **(STEP 7).**
- xiv) Ensure all paper labels and staples upon all timber (Item 1- LTB's) are removed. **(STEP 8).**

5 POST INSTALLATION INSPECTION

CHECK	CHECK	✓
1 The unit is installed at the correct height.	<input type="checkbox"/>	
2 All fixings are tightened and have no protruding sharp edges.	<input type="checkbox"/>	
3 All wooden parts should have no sharp edges or cracks.	<input type="checkbox"/>	
4 Ensure Pivot Bars and Grub Screws are fitted to BTN Bolts.	<input type="checkbox"/>	
5 Ensure all plastic plugs are correctly fitted.	<input type="checkbox"/>	
6 Ensure Manufacturers Label is fitted.	<input type="checkbox"/>	
7 Ensure all paper labels and staples upon all timber are removed.	<input type="checkbox"/>	
8 Concrete foundations are secure.	<input type="checkbox"/>	
9 Concrete has a water shed away from leg.	<input type="checkbox"/>	
10 Adequate provision of Impact Absorbing Surfacing with no obstructions or other hazards within the equipments minimum space.	<input type="checkbox"/>	
11 Site is clear of all tools and rubbish.	<input type="checkbox"/>	
12 Remove any warning signs.	<input type="checkbox"/>	

